

Compact products, whose characteristics are equivalent to that of conventional products

Operating temperature range: -55 to +150°C

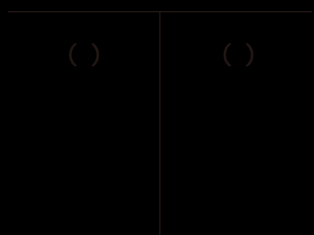

referring to 20K self-heating above ambient temperature

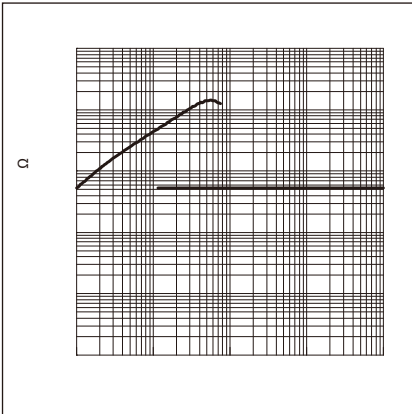
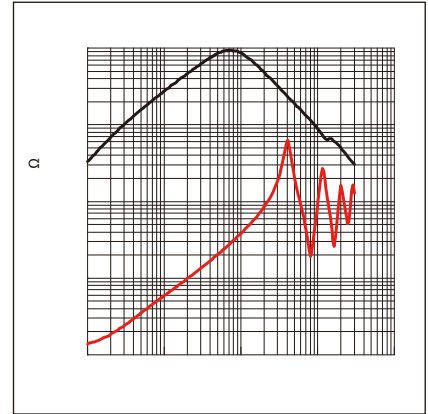
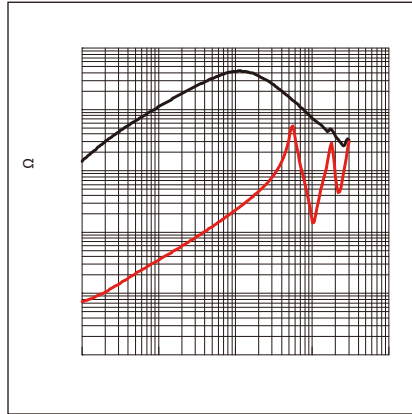
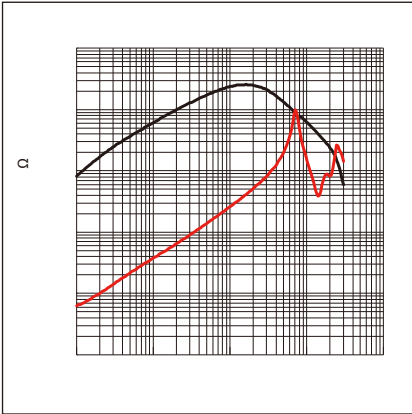

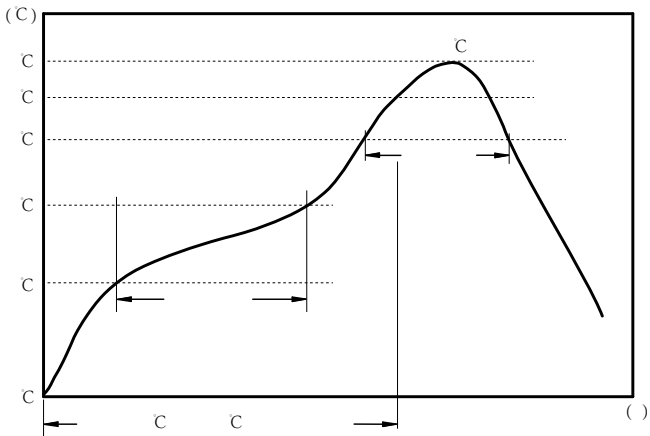

C
C
C

:

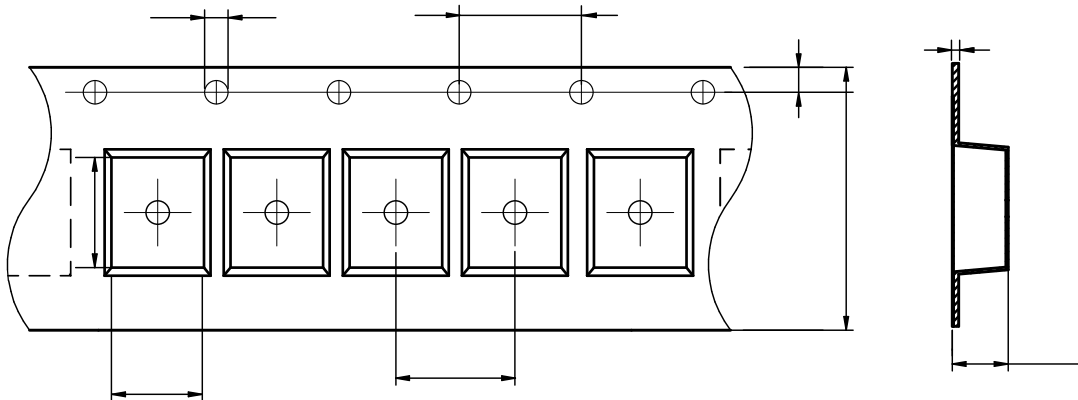

ACMA3225	2.88±0.1	3.72±0.1	1.5±0.1	4.0±0.1	4.0±0.1	8.0±0.3	2.5±0.1	1.75±0.1	0.26±0.05

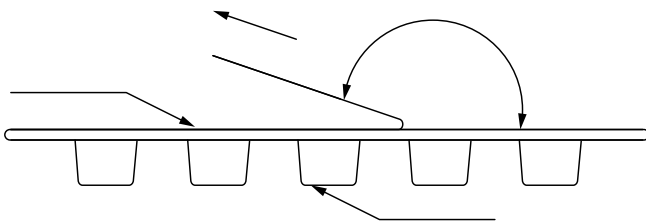

The peel force of top cover tape shall be between 0.14 to 0.78 N

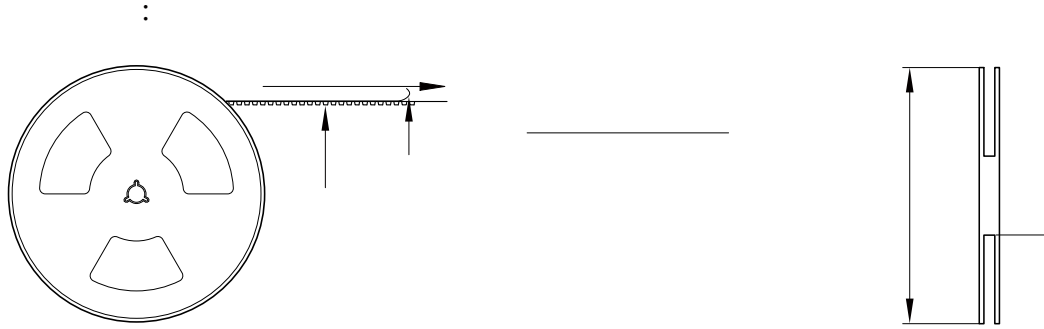

:

-
-
-
-
-
-
-
-
-